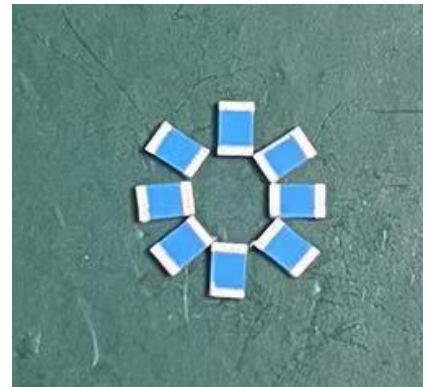

**Application:**

WLAN, 802.11b/g, Bluetooth, etc...

**Features**

SMD, high reliability, ultra Impact, Omni-directional...

**Part number**

KH    2012    F0    P    2G45  
 (1)    (2)    (3)    (4)    (5)

(1)Brand	KH
(2)Size Code	2.0x1.2mm
(3)Type Code	F0
(4)Packing	Paper &Reel
(5)Frequency	2.45GHz
(6)Internal code	

**Electrical Specification**

Working Frequency Range	2400 ~2483MHz
Peak Gain	1.32 dBi (Typ.)
Impedance	50 Ohm
Return loss	10 dB ( Min)
Polarization	Linear
Azimuth Beamwidth	Omni-directional
Operation Temperature(°C)	-40 ~85°C

The specification is defined on EVB.

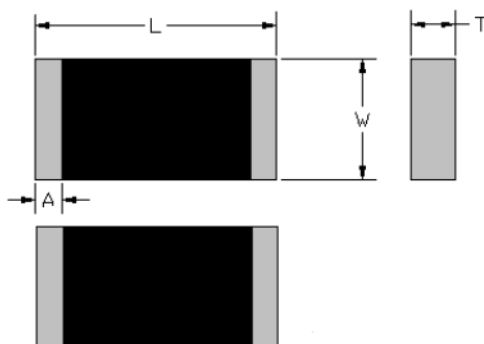
**Dimension and Terminal Configuration**

Dimension (mm)	
L	2.05±0.15
W	1.20±0.15
T	0.50±0.10
A	0.20±0.10

**Evaluation Board Reference**

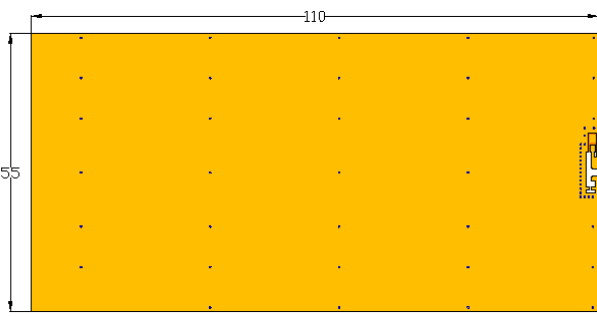
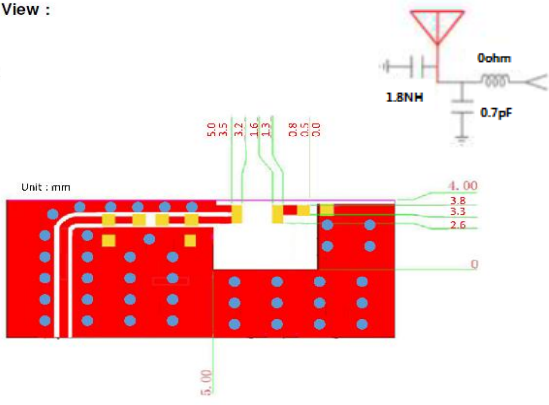
PCB Dimension	Antenna Layout Reference
 <p style="text-align: center;">Unit :mm</p>	<p>2). PCB Top View :</p> <p>Type1 :</p> 

**Electrical Characteristics**

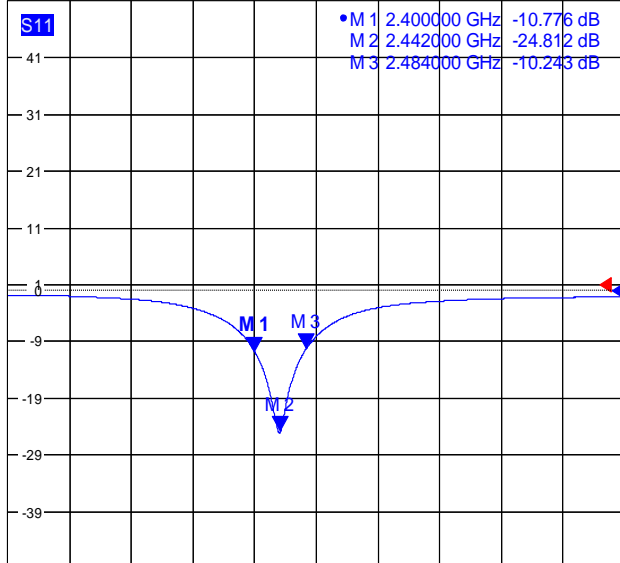
Return Loss & Radiation																	
R	Trc2	dB Mag	10 dB / Ref 0 dB	Invisible	1												
	Trc3	dB Mag	10 dB / Ref 0 dB	Cal int Offs													
<table border="1" style="width: 100%; border-collapse: collapse;"> <thead> <tr> <th>S11</th> <th>Frequency (MHz)</th> <th>S11 (dB)</th> </tr> </thead> <tbody> <tr> <td>M 1</td> <td>2.400000 GHz</td> <td>-10.776 dB</td> </tr> <tr> <td>M 2</td> <td>2.442000 GHz</td> <td>-24.812 dB</td> </tr> <tr> <td>M 3</td> <td>2.484000 GHz</td> <td>-10.243 dB</td> </tr> </tbody> </table>						S11	Frequency (MHz)	S11 (dB)	M 1	2.400000 GHz	-10.776 dB	M 2	2.442000 GHz	-24.812 dB	M 3	2.484000 GHz	-10.243 dB
S11	Frequency (MHz)	S11 (dB)															
M 1	2.400000 GHz	-10.776 dB															
M 2	2.442000 GHz	-24.812 dB															
M 3	2.484000 GHz	-10.243 dB															
																	
Ch1 Start 2 GHz		Pwr 0 dBm		Stop 3 GHz													

Frequency (MHz)	S11 (dB)
2400	-10.78
2442	-24.81
2484	-10.24

**Radiation**

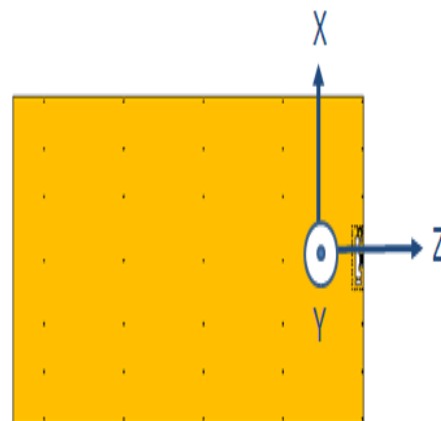
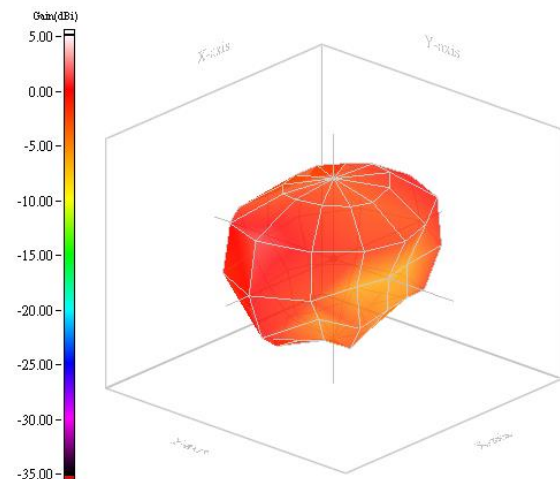

**Taping Specifications**

**Reel and Taping Specification**

**Reel Specification**

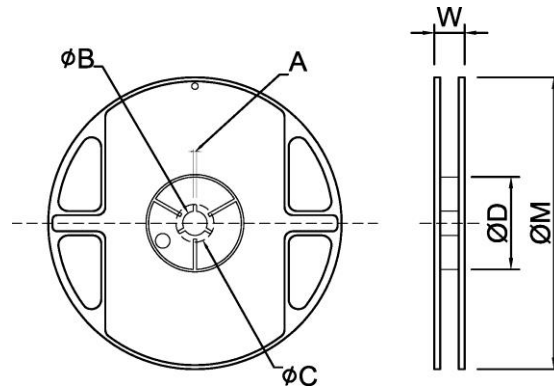

TYPE	SIZE		A	φ B	φ C	φ D	W	φ M
2012	7"	5K/Reel	2.0±0.5	13.5±1.0	21±1.0	60±1.0	11.5±2.0	178±2.0

**Tapping Specification**

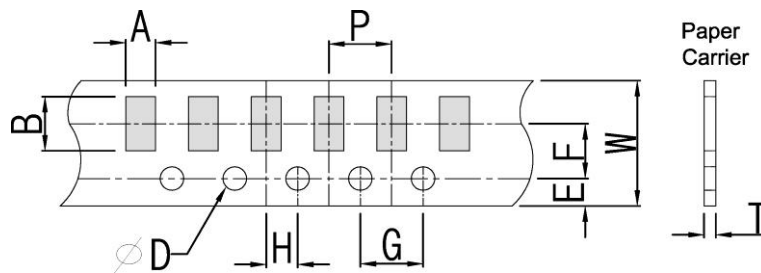

Packaging	Type	A	B	W	E	F	G	H	T	φD	P
Paper Type	2012	1.90±0.20	3.50±0.20	8.0±0.20	1.75±0.10	3.5±0.05	4.0±0.10	2.0±0.05	0.75±0.10	1.50 +0.10 -0	4.0±0.1

**Reliability Table**

Test Item	Procedure	Requirements Ceramic Type	Remark (Reference)
<b>Electrical Characterization</b>		Fulfill the electrical specification	User Spec.
<b>Thermal Shock</b>	1. Preconditioning: $50 \pm 10^\circ\text{C}$ / 1 hr , then keep for $24 \pm 1$ hrs at room temp. 2. Initial measure: Spec: refer Initial spec. 3. Rapid change of temperature test: $-30^\circ\text{C}$ to $+85^\circ\text{C}$ ; 100 cycles; 15 minutes at Lower category temperature; 15 minutes at Upper category temperature.	No Visible Damage. Fulfill the electrical specification.	MIL-STD-202 107
<b>Temperature Cycling</b>	1. Initial measure: Spec: refer Initial spec. 2. 100 Cycles ( $-30^\circ\text{C}$ to $+85^\circ\text{C}$ ), Soak Mode=1 (2 Cycle/hours). 3. Measurement at $24 \pm 2$ Hours after test condition.	No Visible Damage. Fulfill the electrical specification.	JESD22 JA104
<b>High Temperature Exposure</b>	1. Initial measure: Spec: refer Initial spec. 2. Unpowered; 500hours @ $T=+85^\circ\text{C}$ . 3. Measurement at $24 \pm 2$ hours after test.	No Visible Damage. Fulfill the electrical specification.	MIL-STD-202 108
<b>Low Temperature Storage</b>	1. Initial measure: Spec: refer Initial spec. 2. Unpowered: 500hours @ $T= -30^\circ\text{C}$ . 3. Measurement at $24 \pm 2$ hours after test.	No Visible Damage. Fulfill the electrical specification.	MIL-STD-202 108
<b>Solderability (SMD Bottom Side)</b>	Dipping method: a. Temperature: $235 \pm 5^\circ\text{C}$ b. Dipping time: $3 \pm 0.5\text{s}$	The solder should cover over 95% of the critical area of bottom side.	IEC 60384-21/22 4.10
<b>Soldering Heat Resistance (RSH)</b>	Preheating temperature: $150 \pm 10^\circ\text{C}$ . Preheating time: 1~2 min. Solder temperature: $260 \pm 5^\circ\text{C}$ . Dipping time: $5 \pm 0.5\text{s}$	No Visible Damage.	IEC 60384-21/22 4.10
<b>Vibration</b>	5g's for 20 min., 12 cycles each of 3 orientations Note: Use 8"X5" PCB .031" thick 7 secure points on, one long side and 2 secure points at corners of opposite sides. Parts mounted within 2" from any secure point. Test from 10-2000 Hz.	No Visible Damage.	MIL-STD-202 Method 204
<b>Mechanical Shock</b>	Three shocks in each direction shall be applied along the three mutually perpendicular axes of the test specimen (18 shocks) Peak value: 1,500g's Duration: 0.5ms Velocity change: 15.4 ft/s Waveform: Half-sine	No Visible Damage.	MIL-STD-202 Method 213
<b>Humidity Bias</b>	1. Humidity: 85% R.H., Temperature: $85 \pm 2^\circ\text{C}$ . 2. Time: $500 \pm 24$ hours. 3. Measurement at $24 \pm 2$ hrs after test condition.	No Visible Damage. Fulfill the electrical specification.	MIL-STD-202 Method 106

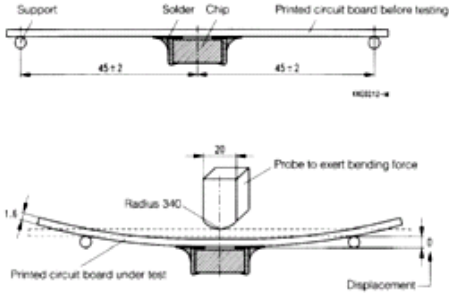
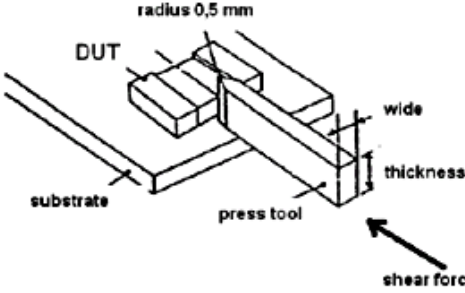
<p><b>Board Flex (SMD)</b></p>	<p>1. Mounting method: IR-Reflow. PCB Size (L:100 × W:40 × T:1.6mm)</p> <p>2. Apply the load in direction of the arrow until bending reaches 2 mm.</p> 	<p>No Visible Damage.</p>	<p>AEC-Q200 005</p>
<p><b>Adhesion</b></p>	<p>Force of 1.8Kg for 60 seconds.</p> 	<p>No Visible Damage Magnification of 20X or greater may be employed for inspection of the mechanical integrity of the device body terminals and body/terminal junction.</p>	<p>AEC-Q200 006</p>
<p><b>Physical Dimension</b></p>	<p>Any applicable method using x10 magnification, micrometers, calipers, gauges, contour projectors, or other measuring equipment, capable of determining the actual specimen dimensions.</p>	<p>In accordance with specification.</p>	<p>JESD22 JB100</p>

**Revision History**

Revision	Date	Content
1	2015/8/20	New issue
2	2017/4/20	Update detail dimension on antenna layout
3	2018/3/1	Part number and coding rule updated