

## 1 产品特点

- 符合IEEE802.3 和ANSIX3.263标准
- 10/100M Bast-T
- 工作温度：0~70℃
- 存储温度：-25~125℃
- SMD 表贴安装
- 回流焊温度：峰值温度≤250℃（10s）
- 回流焊次数：建议不大于3次
- 尺寸：12.7\*7.1\*2mm



## 2 参数表

产品型号	OCL(uH min) @100KHz/0.1V	Turns Ratio(5%)		DCR (Ω) Max 9-10,11-12 13-14,15-16	Cww(Pri:Sec) pF Typ		Isolation Voltage(AC Vrms 3S)
	350UH	1:1		0.9	20		1500V
产品型号	InsertionLoss(dB Max .@4MHz)	Return Loss(dB Min @4MHz)			CMRR(dB min)MHz		Crosstalkm (dB)
		1-30	40~60	60~100	1-60	60~100	1~100
S	-1	-18	-16	-14	-40	-30	-35

## 3 外观尺寸图、原理图

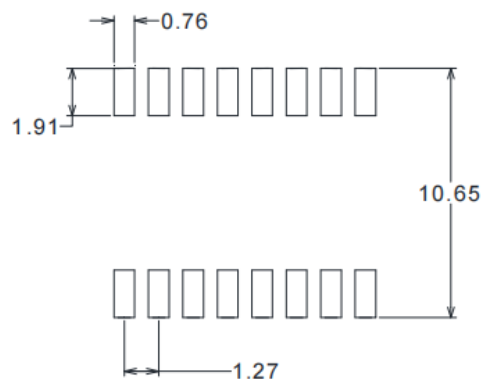
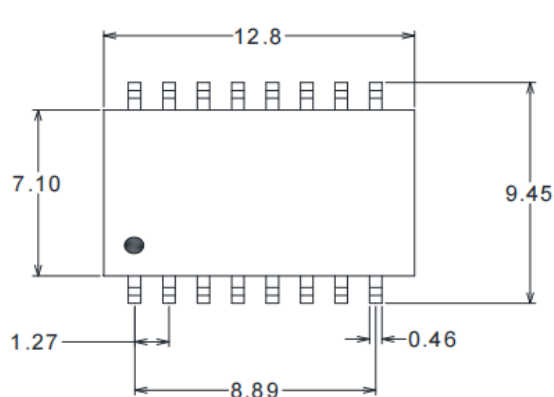

SUGGESTED PAD LAYOUT

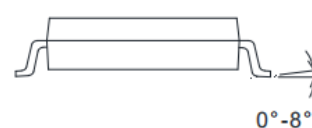
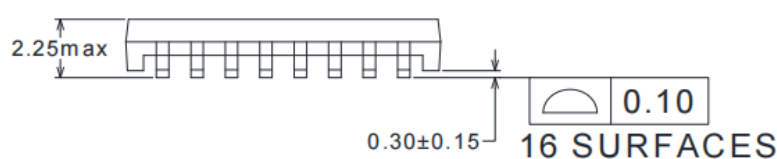

※单位：mm

Unless otherwise specified all tolerances are: ±0.1

4 原理图

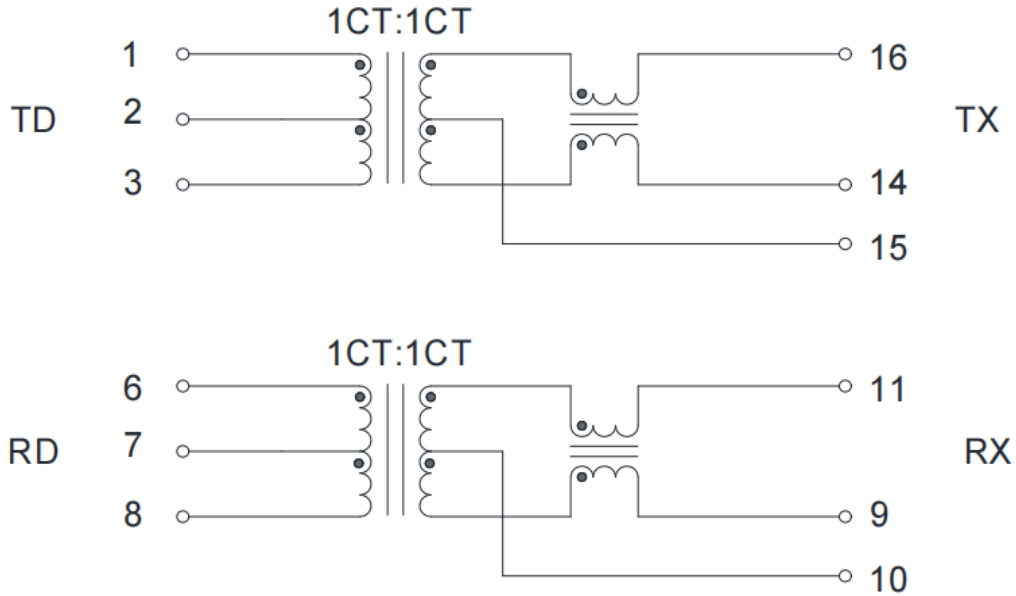

5 包装信息

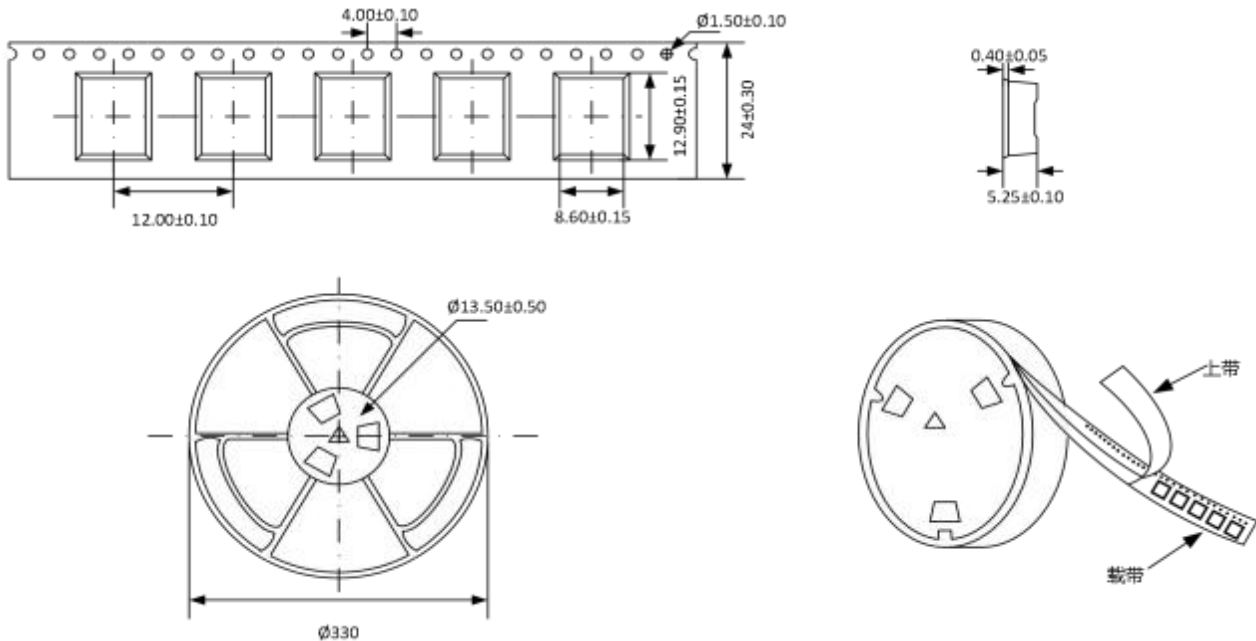

※单位: mm

※包装数量(MOQ): 2000pcs/卷 16000pcs/箱

※外箱尺寸: 410L\*410W\*250H