

1 Features

- Meets IEEE 802.3at and ANSIX3.263 standards .RoHS Compliant
- 10/100 Base-T, Surface Mount Type, Open Header
- Cable interface for isolation and low common mode emissions.
- Reflow soldering temperature: peak temperature $\leq 250\text{ }^{\circ}\text{C}$ (10s)
- Reflow soldering frequency: It is recommended not to exceed 3 times
- Storage temperature range: $-40\text{ }^{\circ}\text{C}$ to $+85\text{ }^{\circ}\text{C}$
- Operating temperature range: $0\text{ }^{\circ}\text{C}$ to $+70\text{ }^{\circ}\text{C}$



2 Specifications (特性参数)

	350UH	1:1		0.9/1.2	35		1500V
		1-30	40~60	60~100	1-60	60~100	1~100
SP	-1.2	-18	-16	-14	-40	-30	-35

3 Mechanical (外观尺寸图)

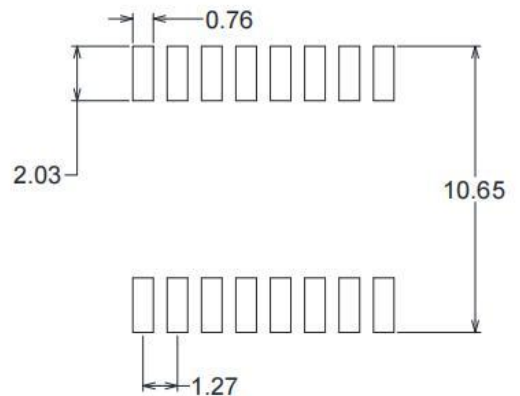
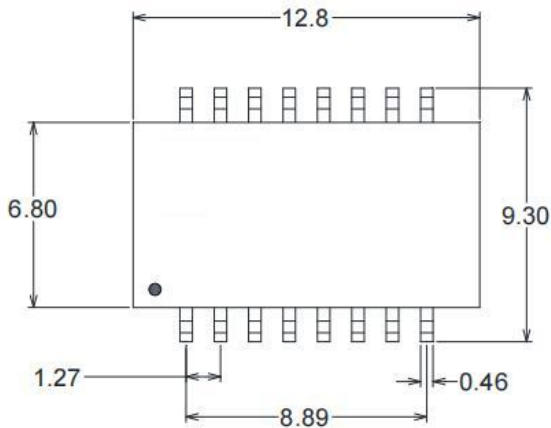

SUGGESTED PAD LAYOUT

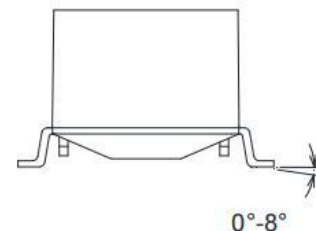
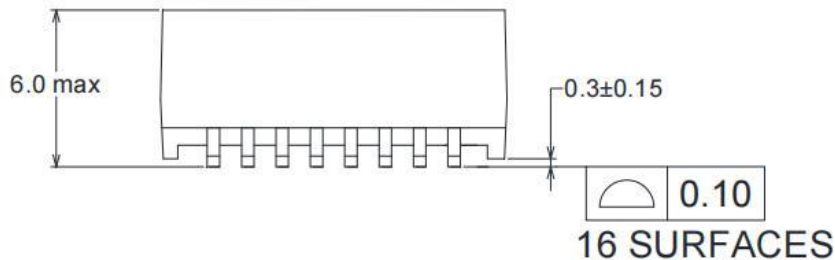

※unit: mm

Unless otherwise specified all tolerances are: ± 0.15

4 Schematic (原理图)

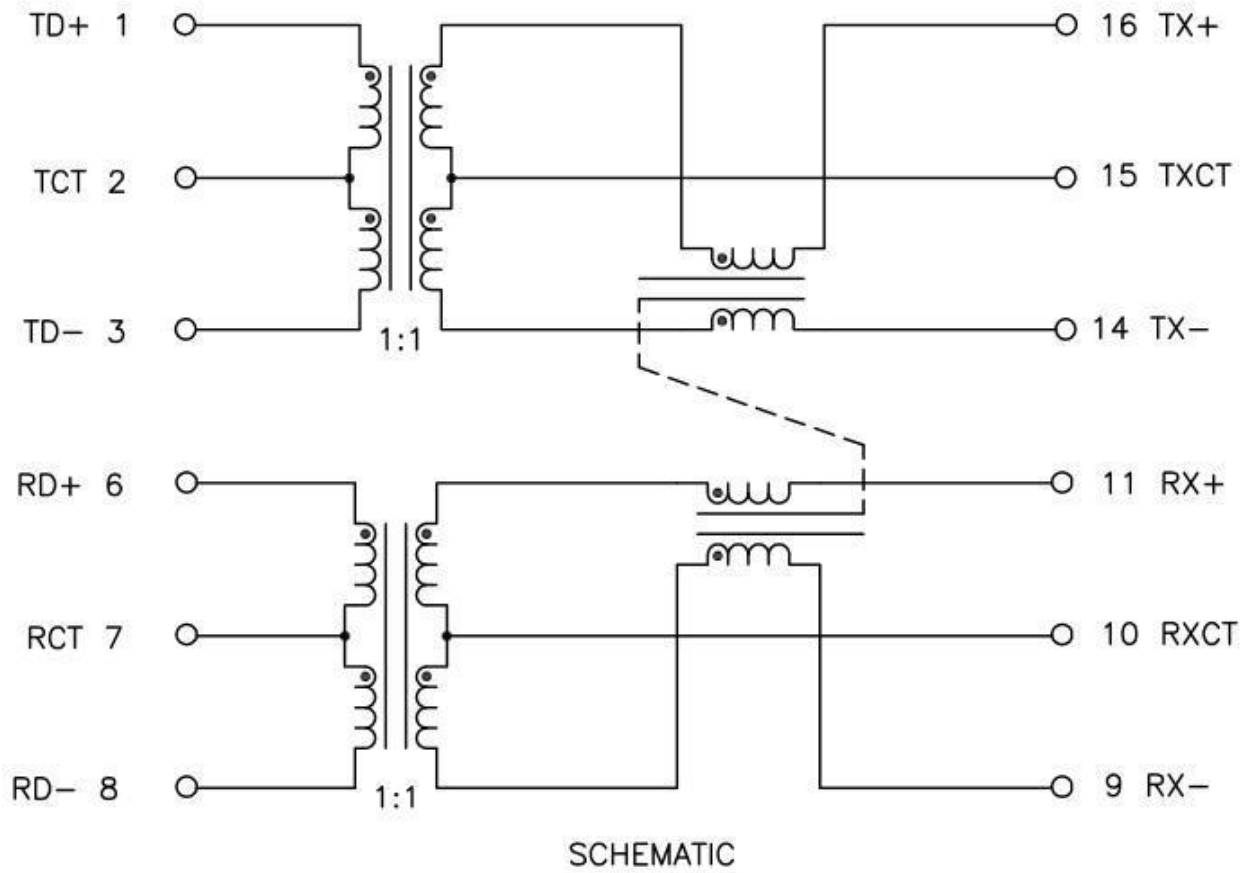

5 packing (包装信息)

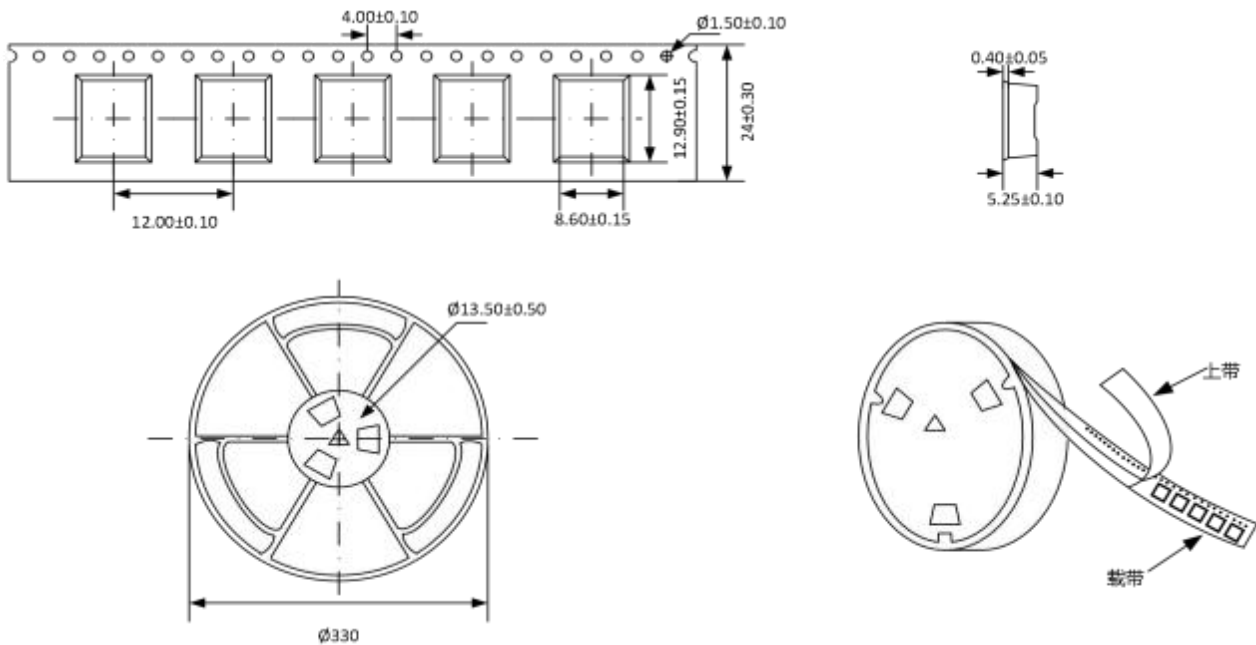

※unit: mm

※ Packaging quantity : 600pcs/roll 4800pcs/box

※ Outer box size: * L * * W * * H